

# FilterQuick™ FQE30

## Electric Fryer

### Wiring Diagrams

This manual is updated as new information and models are released. Visit our website for the latest manual.



8 1 9 7 2 2 5

Part Number: FRY\_D\_8197225 04/15

 **DANGER**

**Prior to movement, testing, maintenance and any repair on your Frymaster fryer, disconnect ALL electrical power from the fryer.**

# FILTERQUICK™ FQE30 SERIES ELECTRIC FRYER

## Table of Contents

---

### SECTION 1: Wiring Diagrams

1.1 Control Wiring .....	1-1
1.2 Contactor Box – Delta Configuration .....	1-2
1.3 Contactor Box – Delta Configuration 14kW/17kW EPRI/TRIAC .....	1-3
1.4 Contactor Box – WYE Configuration .....	1-4
1.5 Contactor Box – WYE Configuration 14kW/17kW EPRI/TRIAC.....	1-5
1.6 Simplified Wiring .....	1-6
1.6.1 Simplified Wiring with Push Button.....	1-6
1.6.2 Simplified Wiring with Push Pull Handles.....	1-7
1.7 Shortening Melting Unit .....	1-8
1.8 Modular Basket Lift 100-120V .....	1-9
1.9 Modular Basket Lift 208-250V .....	1-10

# FILTERQUICK™ FQE30 SERIES ELECTRIC FRYER

## SECTION 1: WIRING DIAGRAMS

### 1.1 Control Wiring

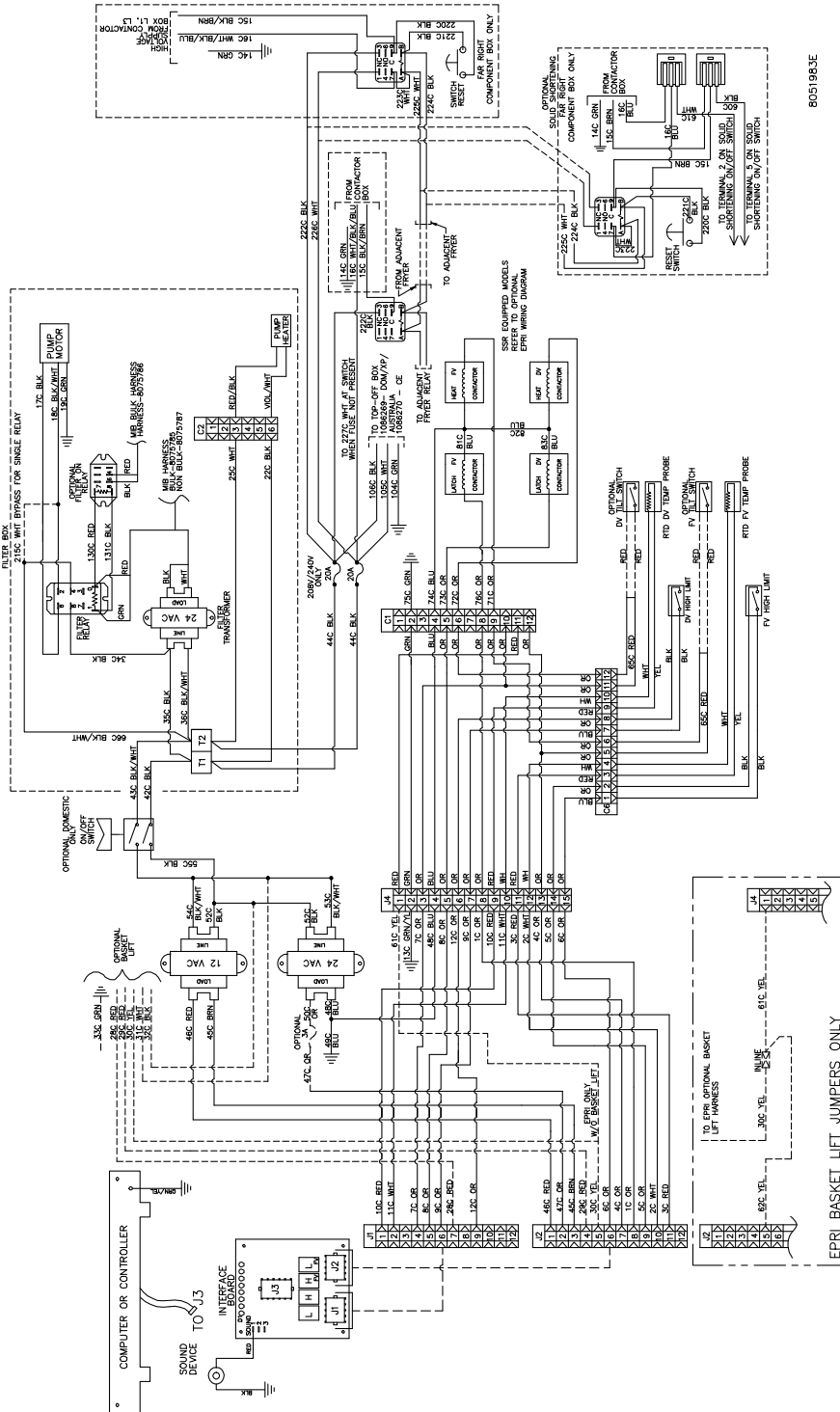

8051983E

## 1.2 Contactor Box – Delta Configuration

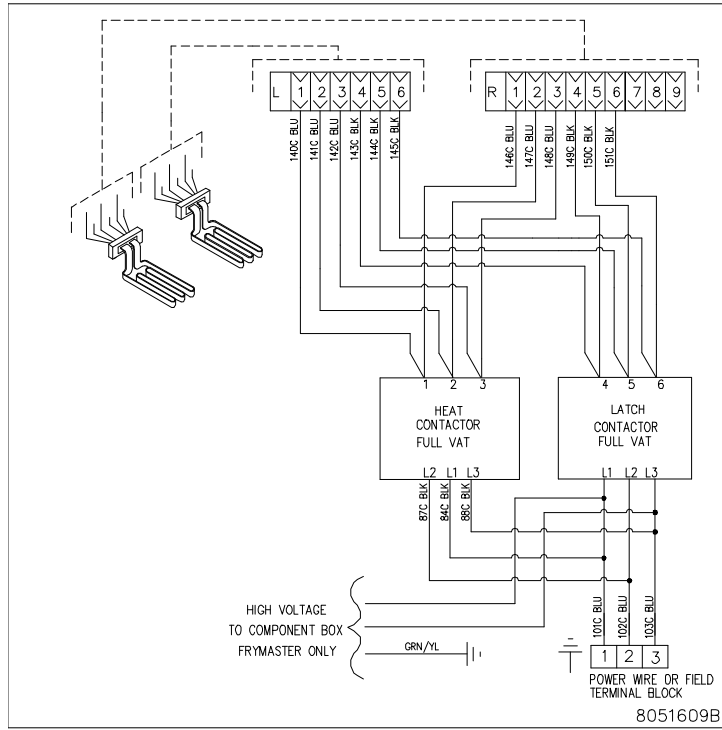

**FULL VAT**

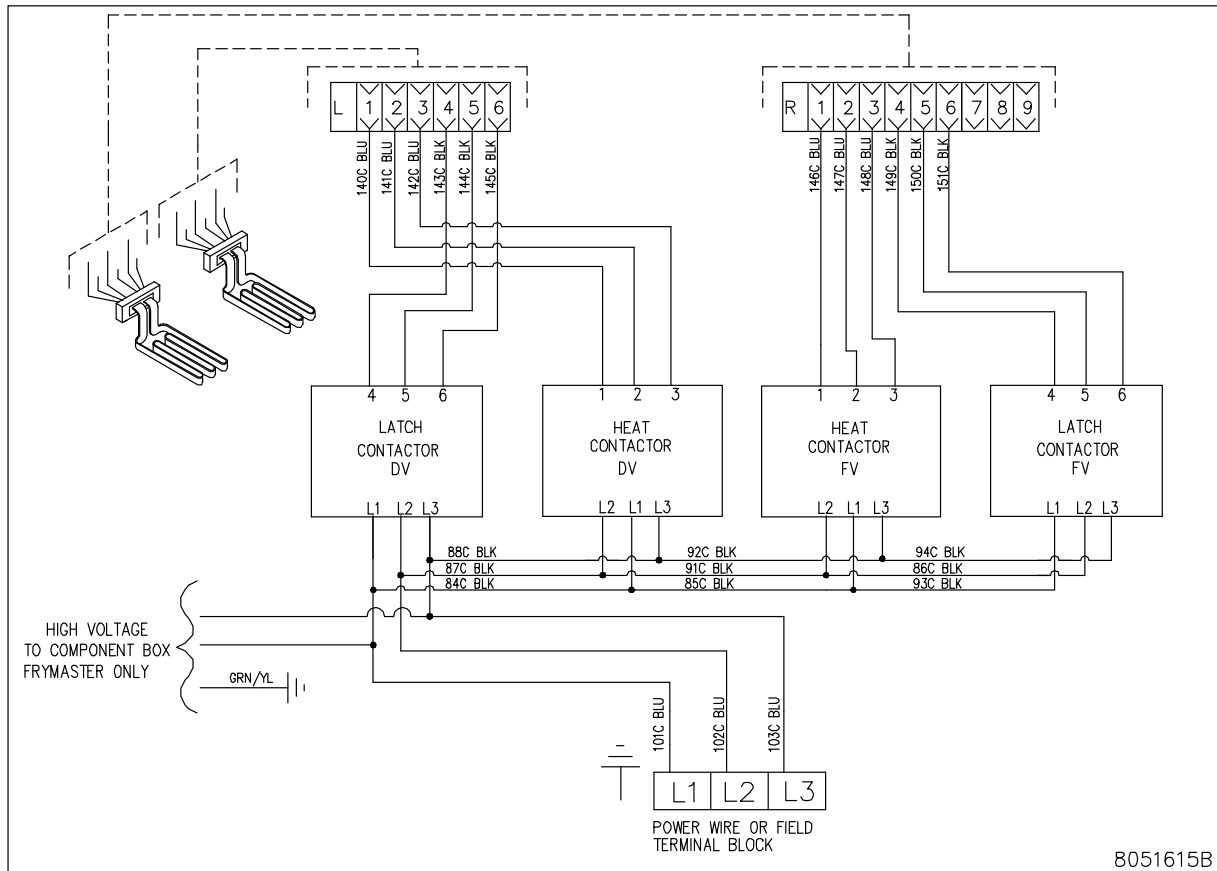

**DUAL VAT**

### 1.3 Contactor Box – Delta Configuration 14kW/17kW EPRI/TRIAC

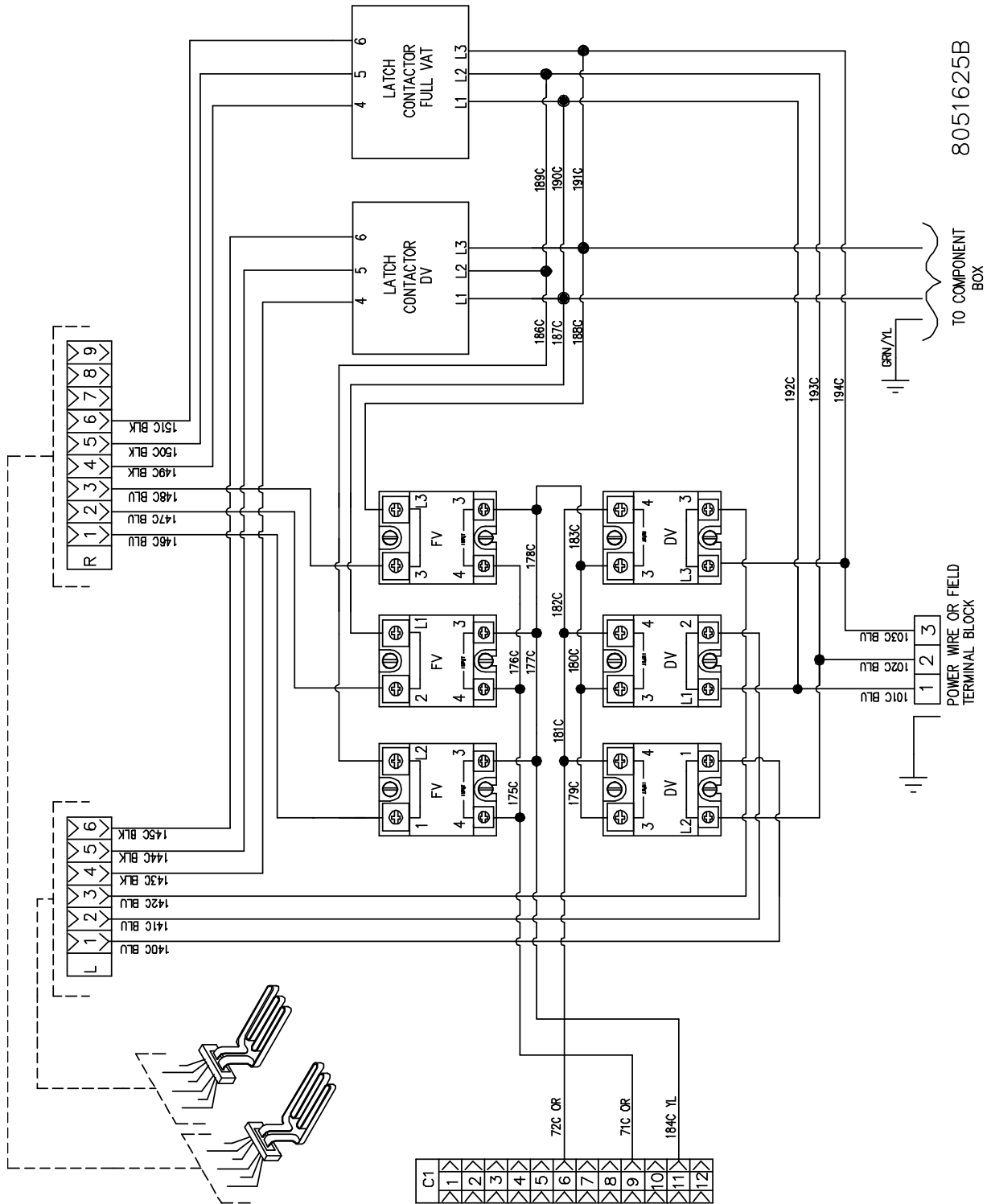

14kW / 17kW EPRI/TRIAC SSR ELEMENT WIRING

# 1.4 Contactor Box – WYE Configuration

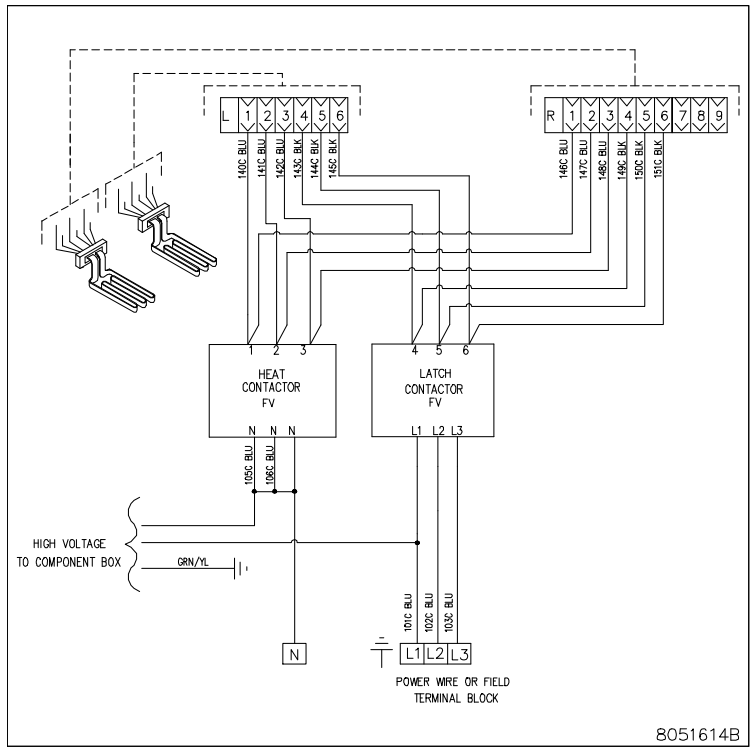

**FULL VAT**

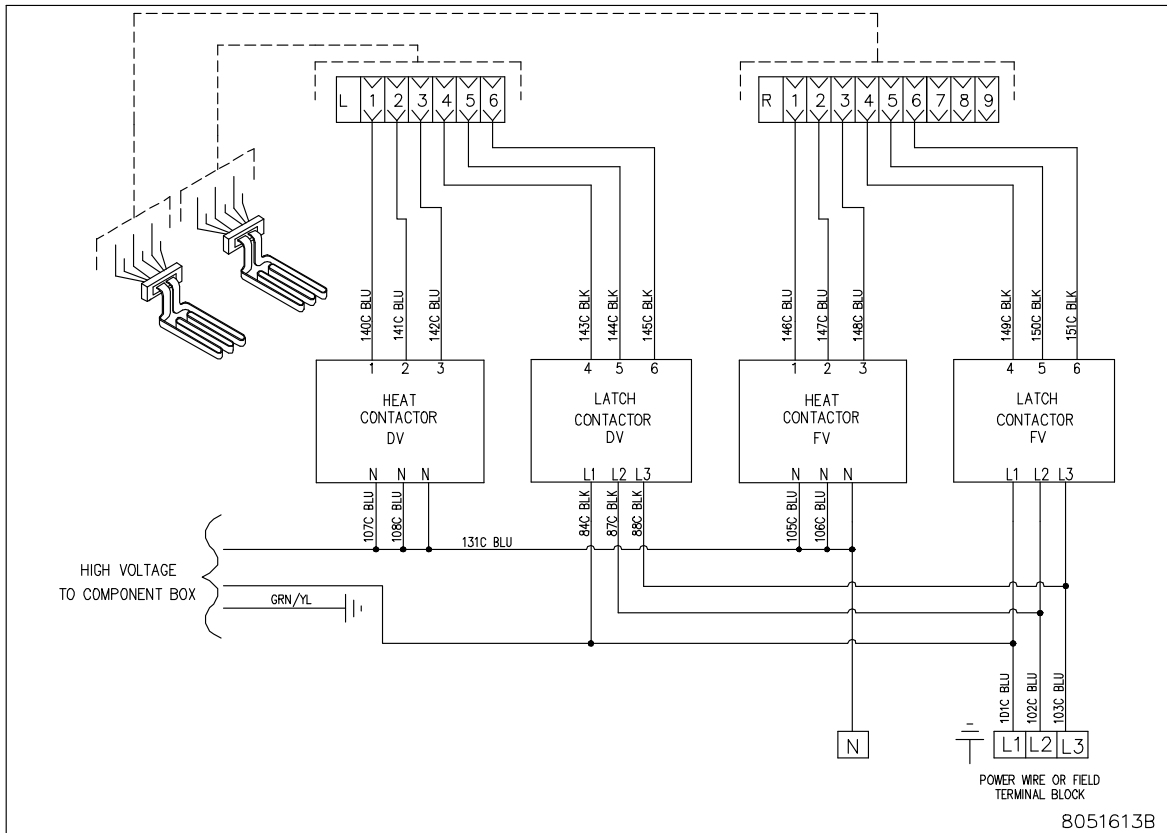

**DUAL VAT**





# 1.6 FilterQuick™ Electric Simplified Wiring

## 1.6.1 FilterQuick™ Electric Simplified Wiring with Push Button

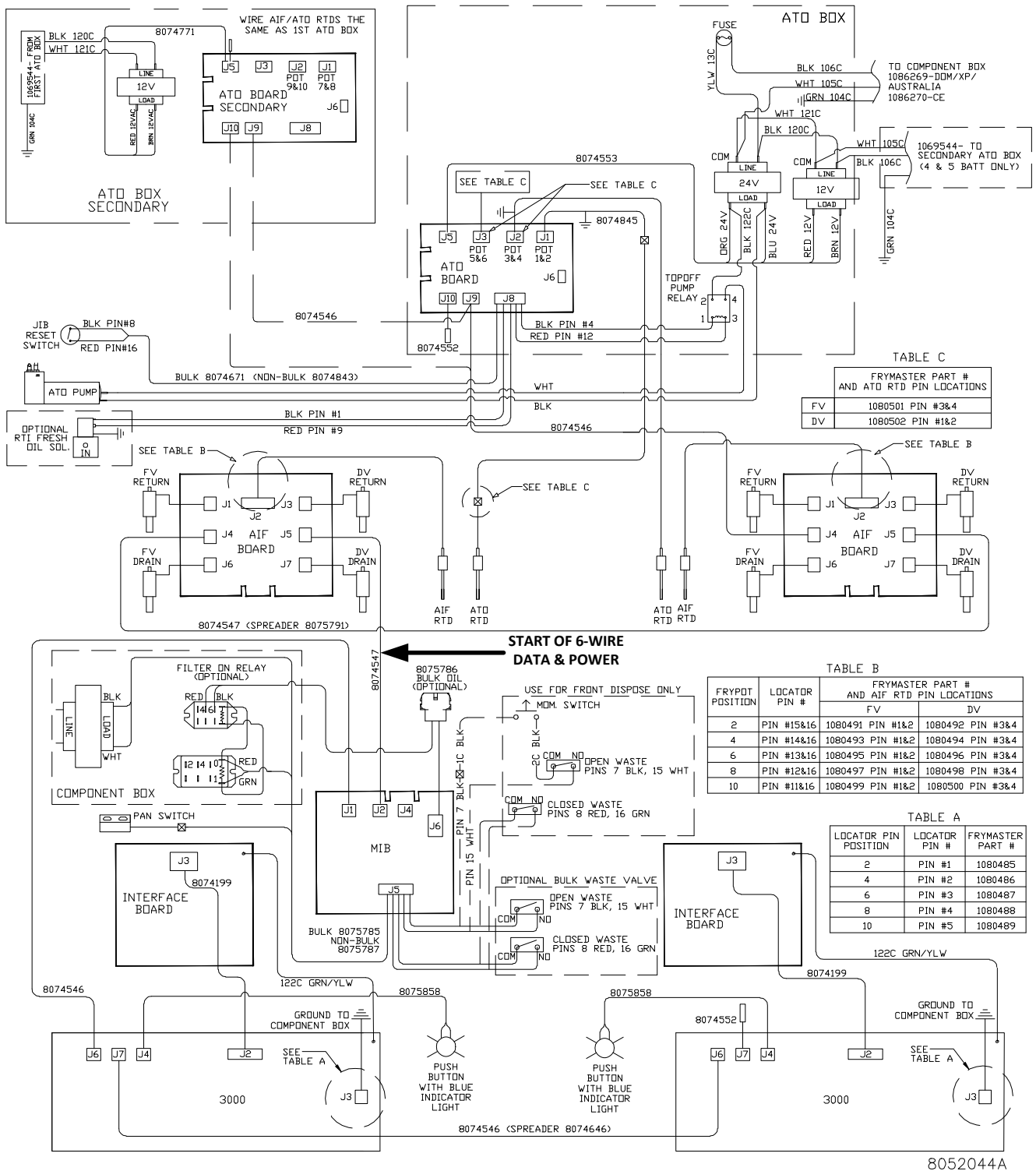

# 1.6.2 FilterQuick™ Electric Simplified Wiring with Push Pull Handles

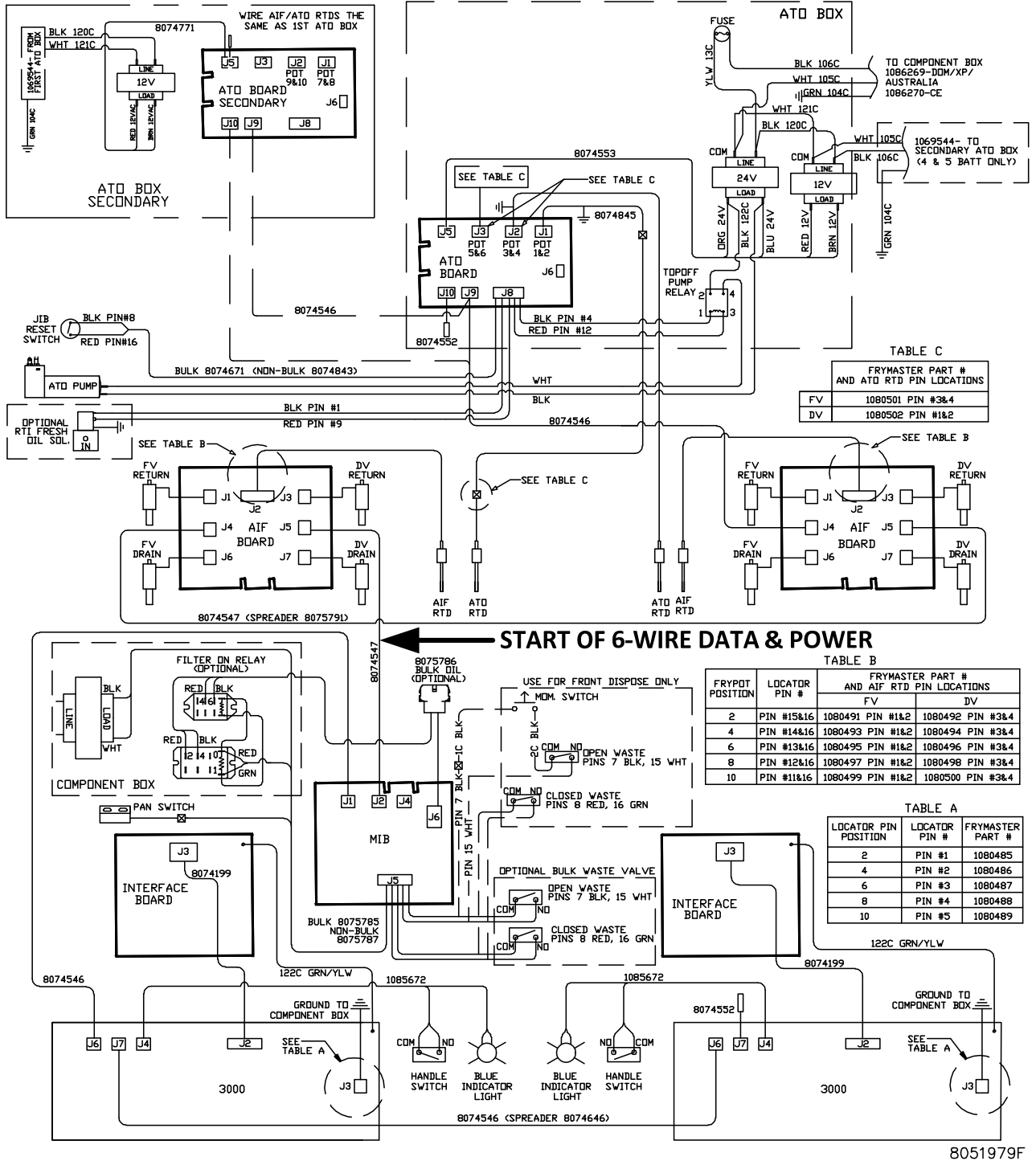

# 1.7 Shortening Melting Unit Wiring Diagram

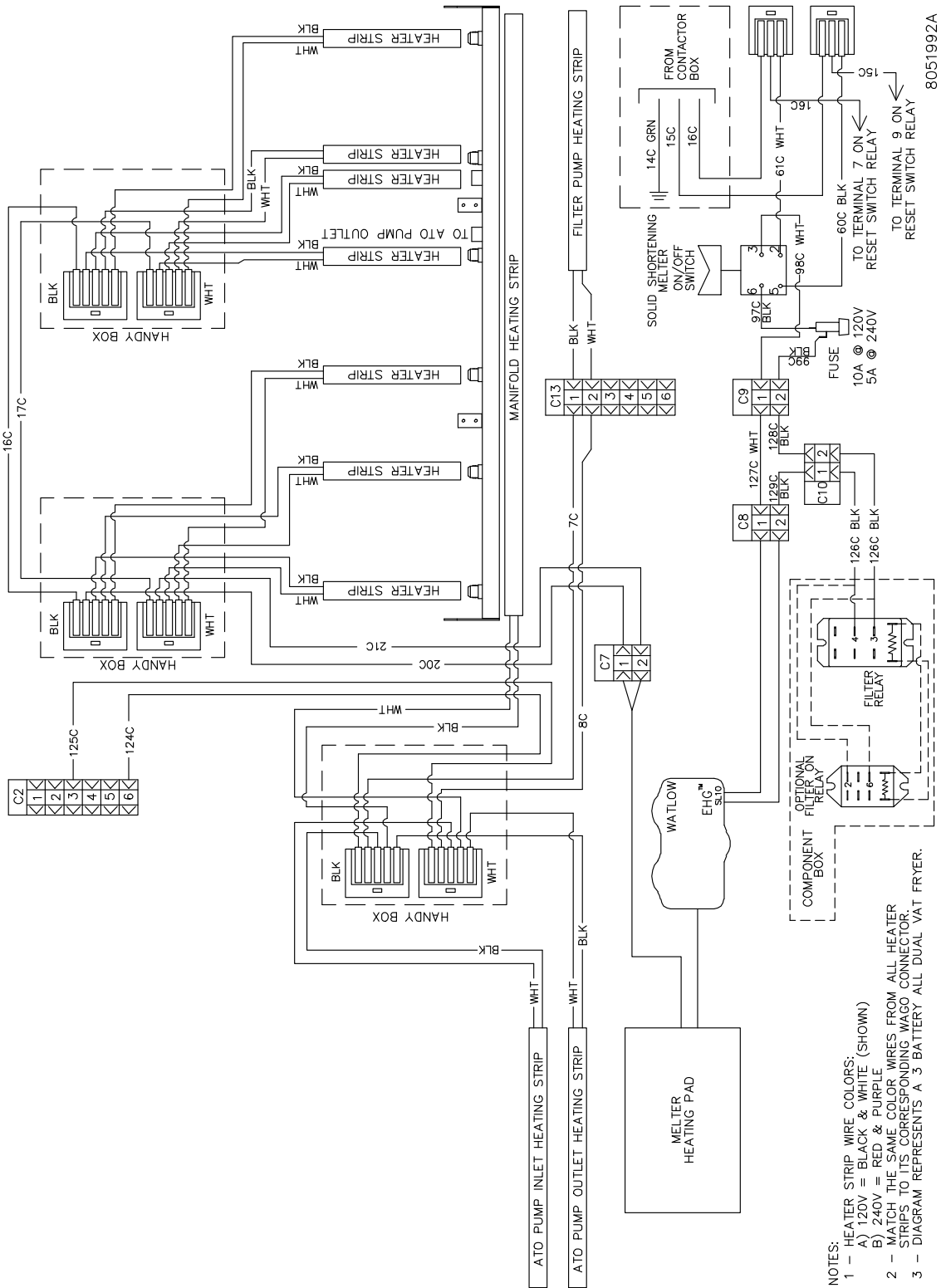

8051992A

# 1.8 Modular Basket Lift Wiring Diagram 100-120V

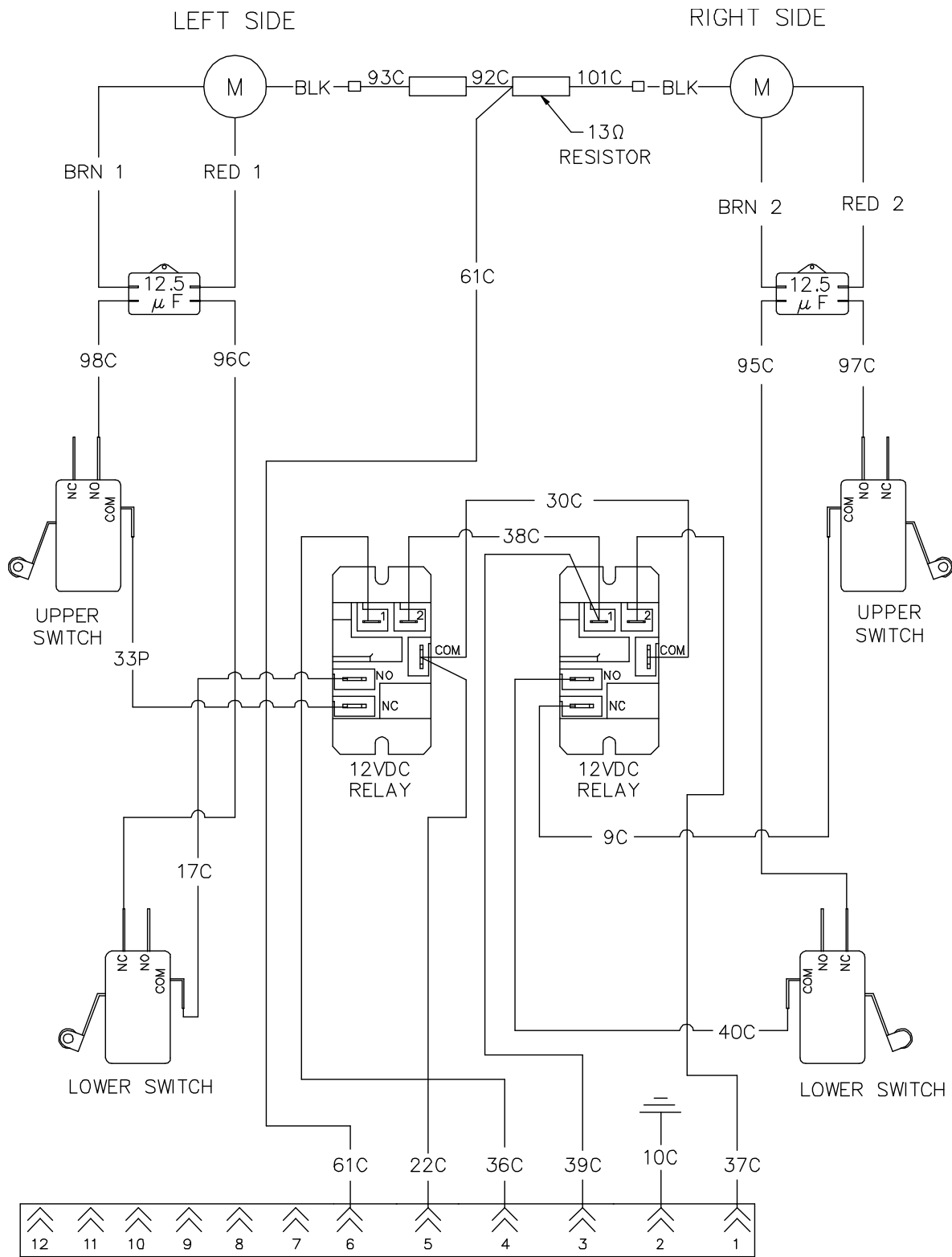

REFERENCES TO LEFT & RIGHT ARE FROM THE REAR OF THE FRYER

8050555E

# 1.9 Modular Basket Lift Wiring Diagram 208-250V

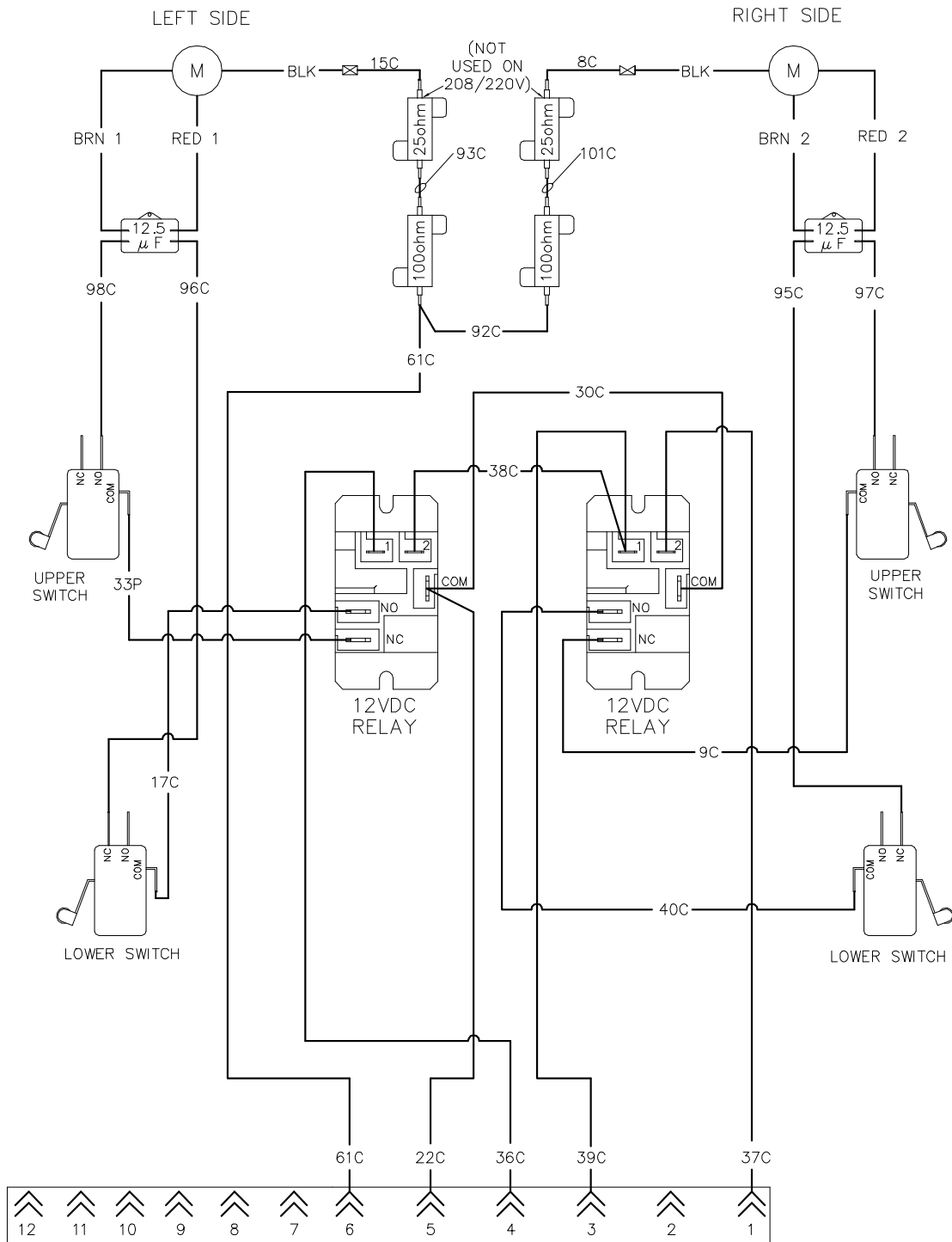

REFERENCES TO LEFT & RIGHT ARE FROM THE REAR OF THE FRYER

8050888D



FRYMASTER  
8700 LINE AVENUE, SHREVEPORT, LA 71106-6800

318-865-1711  
844-724-CARE (2273)  
[WWW.FRYMASTER.COM](http://WWW.FRYMASTER.COM)  
EMAIL: [SERVICE@FRYMASTER.COM](mailto:SERVICE@FRYMASTER.COM)



Every new piece of Manitowoc Foodservice equipment comes with KitchenCare™ and you choose the level of service that meets your operational needs from one restaurant to multiple locations.

**StarCare** – Warranty & lifetime service, certified OEM parts, global parts inventory, performance audited

**ExtraCare** – CareCode, 24/7 Support, online/mobile product information

**LifeCare** – Install & equipment orientation, planned maintenance, KitchenConnect™, MenuConnect

**Talk with KitchenCare™** - 1-844-724-CARE - [www.mtwkitchencare.com](http://www.mtwkitchencare.com)



To learn how Manitowoc Foodservice and its leading brands can equip you, visit our global web site at [www.manitowocfoodservice.com](http://www.manitowocfoodservice.com), then discover the regional or local resources available to you.

